

I-T Characteristics / 時間-電流特性

Ampere Rating 額定電流	% of Ampere Rating 額定電流%	Opening Time 熔斷時間
100mA~6.3A	150%	1 Hr Min. / 最短1小時
8A~15A		30min Min. / 最短30分鐘
100mA~15A	210%	2min Max. / 最長2分鐘
100mA	275%	200ms Min. 10s Max. / 最短200毫秒,最長10秒
125mA~15A		600ms Min. 10s Max. / 最短600毫秒,最長10秒
100mA	400%	40ms Min. 3s Max. / 最短40毫秒,最長3秒
125mA~15A		150ms Min. 3s Max. / 最短150毫秒,最長3秒
100mA	1000%	10ms Min. 300ms Max. / 最短10毫秒,最長300毫秒
125mA~15A		20ms Min. 300ms Max. / 最短20毫秒,最長300毫秒

In accordance with IEC60127-2 standard, sheet3 / 遵循IEC60127-2, 規格單3



Product Features / 產品特性

Materials 材質	Body / 本體: glass tube / 玻璃管 Lead / 引線: tinned copper wire / 鍍錫銅線 Cap / 銅帽: brass with nickel plated / 銅鍍鎳 Element / 熔絲: alloy / 合金線
Operating Temperature 操作溫度	-55°C to +125°C (consider de-rating / 需考慮溫度折減)
Solderability 可焊性	260°C, ≤ 3s. (wave / 波峰焊) 350±10°C, ≤ 3s. (soldering iron / 烙鐵焊)
Resistance to Soldering Heat 耐焊接熱	260°C, 10s. (wave / 波峰焊) 350°C, 5s. (soldering iron / 烙鐵焊)
Recommended Soldering Parameters 建議錫焊參數	Wave soldering parameter / 波峰焊 Soldering pot temperature / 錫爐溫度: 260°C Max Solder dwell time / 焊接時間: 2~5s Hand welding parameter / 手工焊 Soldering iron temperature / 烙鐵溫度: 350±5°C Solder dwell time / 焊接時間: 5s Max.
Storage Conditions 儲存條件	Can be stored for 3 years under tight seal condition at temperature of +10°C~60°C, relative humidity ≤ 75%. 在溫度+10°C~60°C,相對濕度 ≤ 75% 的密閉條件下可存放 3 年。 At most can be kept 30 days at temperature +10°C~60°C, relative humidity ≤ 95% under covered conditions. 在溫度+10°C~60°C, 相對濕度為 95% 的非露天最多可存放 30 天。

Dimensions / 尺寸圖 (Unit / 單位:mm)

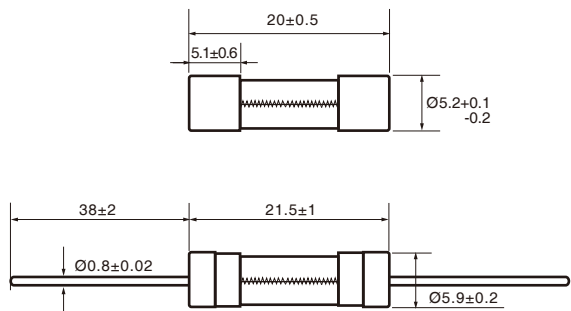

Electrical Characteristics / 電氣特性

Type 型號	Rated Current 額定電流	Rated Voltage 額定電壓	Breaking Capacity 分斷能力	Safety Approvals 安全認證							
				UL US	D'E	VDE	CCC	CQC	CCC	PS	JET
TMD	100mA	250V	100mA~3.15A 35A@250V AC	●	●	●	●	●	●	●	●
TMD	125mA	250V		●	●	●	●	●	●	●	●
TMD	160mA	250V		●	●	●	●	●	●	●	●
TMD	200mA	250V		●	●	●	●	●	●	●	●
TMD	250mA	250V		●	●	●	●	●	●	●	●
TMD	315mA	250V		●	●	●	●	●	●	●	●
TMD	400mA	250V		●	●	●	●	●	●	●	●
TMD	500mA	250V		●	●	●	●	●	●	●	●
TMD	630mA	250V		●	●	●	●	●	●	●	●
TMD	800mA	250V		●	●	●	●	●	●	●	●
TMD	1.00A	250V		●	●	●	●	●	●	●	●
TMD	1.25A	250V		●	●	●	●	●	●	●	●
TMD	1.60A	250V		●	●	●	●	●	●	●	●
TMD	2.00A	250V		●	●	●	●	●	●	●	●
TMD	2.50A	250V		●	●	●	●	●	●	●	●
TMD	3.15A	250V	●	●	●	●	●	●	●	●	
TMD	4.00A	250V	4A~15A 10IN@250V AC	●	●	●	●	●	●	●	
TMD	5.00A	250V		●	●	●	●	●	●	●	
TMD	6.30A	250V		●	●	●	●	●	●	●	
TMD	8.00A	125V/250V		●	●	●	●	●	●	●	
TMD	10.0A	125V/250V		●	●	●	●	●	●	●	
TMD	12.0A	125V/250V		●	●	●	●	●	●	●	
TMD	12.5A	250V		●	●	●	●	●	●	●	
TMD	15.0A	125V/250V		●	●	●	●	●	●	●	

Remark: 125V Voltage only for UL US, D'E, VDE and PS. (1A~10A)